

ELECTRICAL COMPONENTS

INSTALLATION INSTRUCTIONS

MS 4T60E Master Solenoid Kit

*** NOTE:** There are no diodes in the OEM or Teckpak solenoids. Therefore, it does not make any difference which wire is attached to which side of the solenoid.

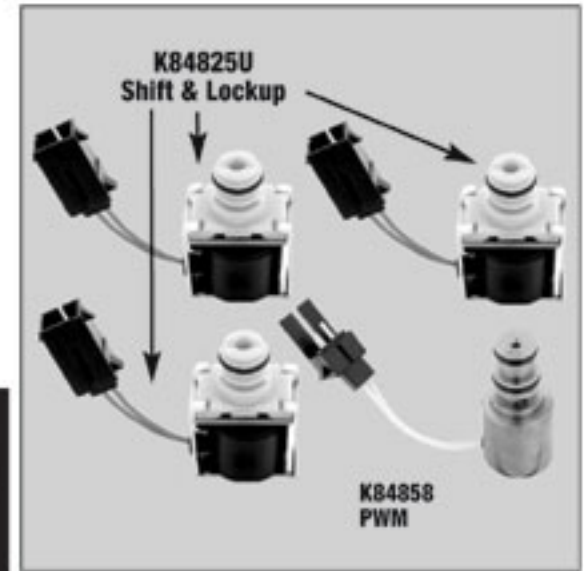

- 1. To Remove:** Label each pair of wires on the harness. Unplug the shift and PWM solenoids. **DO NOT CUT WIRES.** All the solenoids are compatible.

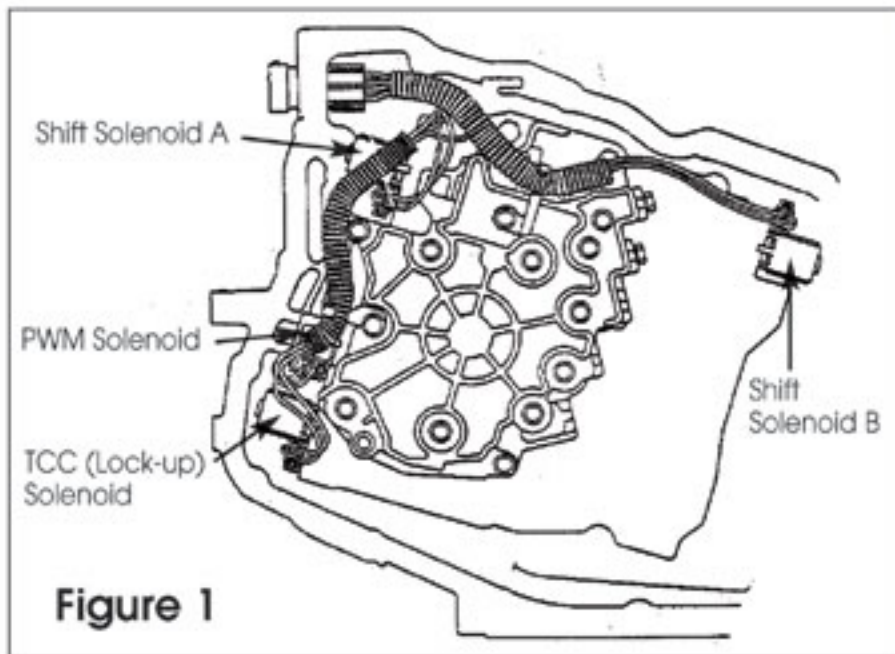

- 2.** Remove the shift, lock-up, TCC and PWM solenoids by removing the retaining clips and pulling them out. Note that the PWM Solenoid has a larger retaining clip. (Figure 2).

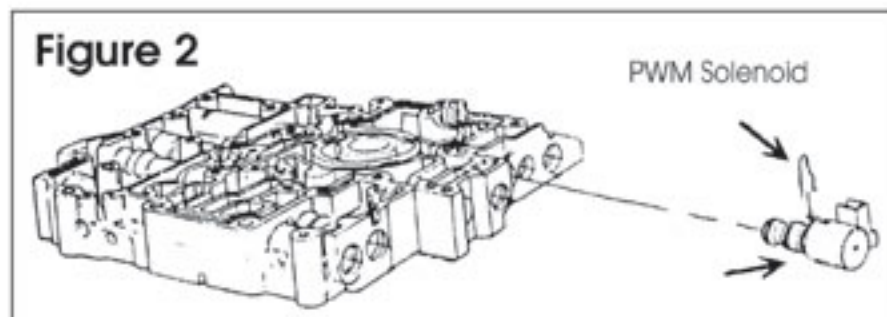

- 3. To Install:** Press all of the solenoids into the valve body in the positions shown in (Figure 1). Insert the clips. Make sure shift solenoids **A** & **B** are pushed in all the way before installing U-clip. The new shift solenoids are interchangeable with each other, but the labeled wire pairs on the harness must be connected to the solenoid in the corresponding shift bore. The PWM has only one position.

- 4. To Connect:** Take the inner connector with the brass spades into the harness. Then pull the cover connector over the inner connector until it snaps in on the harness plug.